

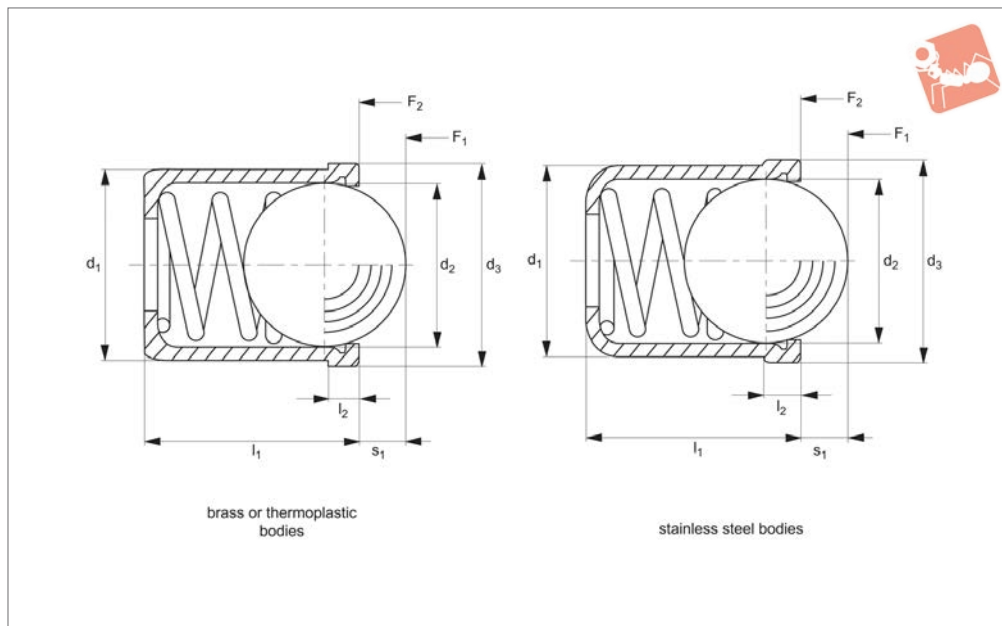

# Spring Plungers

smooth model, with collar and ball- stainless steel

# Spring Plungers



## 32300

SPRING PLUNGERS

### Material

Body: stainless steel 1.4303 (AISI 305), brass, or thermoplastic POM, blue.  
 Ball: ball bearing steel 1.3505 (100Cr6) hardened or thermoplastic POM, white.  
 Spring: stainless steel 1.4568 (X7CrNiAl17-7).

### Technical Notes

Used for locating, applying pressure or

lifting off.

Spring loads \* = statistical average values.  
 Thermo type temperature range -30°C to +50°C.  
 Stainless and brass type, temperature range max. 250°C.  
 For calculation of indexing resistance please refer to spring plunger technical pages.

### Tips

These are press fit spring plungers. Typical hole tolerance is H7 for manual assembly. These fit tolerances vary with type of material so a trial hole is recommended. Light spring load- marked with one line. Standard spring load- no marking. Heavy spring load- marked with two lines. Special types available on request.

Order No.	Spring load	Finish	d <sub>1</sub> -0 +0.1	d <sub>2</sub>	d <sub>3</sub>	l <sub>1</sub>	l <sub>2</sub> ≈	s <sub>1</sub>	Spring load		Temperature °C max.	Weight g
									F <sub>1</sub> N ≈	F <sub>2</sub> N ≈		
32300.W0003	Standard	Body & Ball Stainless	3	2,38	3,5	4,0	0,60	0,70	1,8	3,5	+250	0,20
32300.W0004	Standard	Body & Ball Stainless	4	3,00	4,6	5,0	0,90	1,00	2,5	6,0	+250	0,30
32300.W0005	Standard	Body & Ball Stainless	5	4,00	5,6	6,0	0,90	1,40	3,0	6,5	+250	0,60
32300.W0006	Standard	Body & Ball Stainless	6	5,00	6,5	7,0	1,00	1,80	5,5	11,5	+250	1,00
32300.W0008	Standard	Body & Ball Stainless	8	6,50	8,5	9,0	1,10	2,40	7,0	12,5	+250	2,10
32300.W0010	Standard	Body & Ball Stainless	10	8,50	11,0	13,0	1,50	3,30	8,5	18,5	+250	4,40
32300.W0012	Standard	Body & Ball Stainless	12	10,00	13,0	16,0	2,30	4,00	12,0	26,5	+250	7,30
32300.W0203	Standard	Body Brass, Ball Stainless	3	2,38	3,6	4,0	0,60	0,60	1,8	3,5	+250	0,20
32300.W0204	Standard	Body Brass, Ball Stainless	4	3,00	4,5	5,0	1,00	0,80	3,0	6,0	+250	0,50
32300.W0205	Standard	Body Brass, Ball Stainless	5	4,00	5,5	6,0	1,00	1,00	4,0	6,5	+250	0,80
32300.W0206	Standard	Body Brass, Ball Stainless	6	5,00	6,5	7,0	1,00	1,60	6,0	11,5	+250	1,30
32300.W0208	Standard	Body Brass, Ball Stainless	8	6,50	8,5	9,0	1,00	1,90	8,0	12,5	+250	2,80
32300.W0403	Standard	Body Thermo, Ball S/S	3	2,00	3,6	4,0	0,60	0,55	1,7	3,5	-30/+50	0,09
32300.W0404	Standard	Body Thermo, Ball S/S	4	3,00	4,6	5,0	1,00	0,80	3,0	6,5	-30/+50	0,20
32300.W0405	Standard	Body Thermo, Ball S/S	5	4,00	5,6	6,0	1,00	1,00	6,0	9,4	-30/+50	0,40
32300.W0406	Standard	Body Thermo, Ball S/S	6	5,00	6,5	7,0	1,00	1,60	6,2	12,6	-30/+50	0,70
32300.W0408	Standard	Body Thermo, Ball S/S	8	6,50	8,5	9,0	1,00	1,90	10,0	20,4	-30/+50	1,50
32300.W0410	Standard	Body Thermo, Ball S/S	10	8,00	11,0	13,5	1,50	2,40	11,9	22,3	-30/+50	3,20
32300.W0412	Standard	Body Thermo, Ball S/S	12	10,00	13,0	16,0	1,50	3,30	14,0	25,0	-30/+50	5,80
32300.W0604	Standard	Body & Ball Thermoplast	4	3,00	4,6	5,0	1,00	0,80	3,0	6,5	-30/+50	0,10
32300.W0605	Standard	Body & Ball Thermoplast	5	4,00	5,6	6,0	1,00	1,00	6,0	9,4	-30/+50	0,20
32300.W0606	Standard	Body & Ball Thermoplast	6	5,00	6,5	7,0	1,00	1,60	6,2	12,6	-30/+50	0,30
32300.W0608	Standard	Body & Ball Thermoplast	8	6,50	8,5	9,0	1,00	1,90	10,0	20,4	-30/+50	0,60
32300.W0610	Standard	Body & Ball Thermoplast	10	8,00	11,0	13,5	1,50	2,40	11,9	22,3	-30/+50	1,50
32300.W0612	Standard	Body & Ball Thermoplast	12	10,00	13,0	16,0	1,50	3,30	14,0	25,0	-30/+50	2,50
32300.W1003	Light	Body Brass, Ball Stainless	3	2,38	3,5	4,0	0,6	0,70	0,4	1,3	250	0,1



Order No.	Spring load	Finish	d <sub>1</sub> -0 +0.1	d <sub>2</sub>	d <sub>3</sub>	l <sub>1</sub>	l <sub>2</sub> ≈	s <sub>1</sub>	Spring load	Spring load	Temperature °C max.	Weight g
									F <sub>1</sub> N ≈	F <sub>2</sub> N ≈		
<b>32300.W1004</b>	Light	Body & Ball Stainless	4	3,00	4,6	5,0	0,90	1,00	0,4	1,0	250	0,30
<b>32300.W1005</b>	Light	Body & Ball Stainless	5	4,00	5,6	6,0	0,90	1,40	0,5	4,7	250	0,60
<b>32300.W1006</b>	Light	Body & Ball Stainless	6	5,00	6,5	7,0	1,00	1,80	2,3	6,5	250	1,00
<b>32300.W1008</b>	Light	Body & Ball Stainless	8	6,50	8,5	9,0	1,10	2,40	4,0	9,0	250	2,10
<b>32300.W1010</b>	Light	Body & Ball Stainless	10	8,50	11,0	13,0	1,50	3,30	3,9	10,0	250	4,40
<b>32300.W1012</b>	Light	Body & Ball Stainless	12	10,00	13,0	16,0	2,30	4,00	6,2	14,6	250	7,30
<b>32300.W2004</b>	Heavy	Body & Ball Stainless	4	3,00	4,6	5,0	0,90	1,00	5,0	10,4	+250	0,30
<b>32300.W2005</b>	Heavy	Body & Ball Stainless	5	4,00	5,6	6,0	0,90	1,40	6,0	12,0	+250	0,60
<b>32300.W2006</b>	Heavy	Body & Ball Stainless	6	5,00	6,5	7,0	1,00	1,80	7,3	19,0	+250	1,00
<b>32300.W2008</b>	Heavy	Body & Ball Stainless	8	6,50	8,5	9,0	1,10	2,40	11,0	25,0	+250	2,10
<b>32300.W2010</b>	Heavy	Body & Ball Stainless	10	8,50	11,0	13,0	1,50	3,30	17,0	37,0	+250	4,40
<b>32300.W2012</b>	Heavy	Body & Ball Stainless	12	10,00	13,0	16,0	2,30	4,00	28,0	57,0	+250	7,30

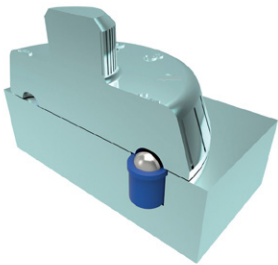



## Wixroyd Spring Plungers - A Range of Endless Possibilities

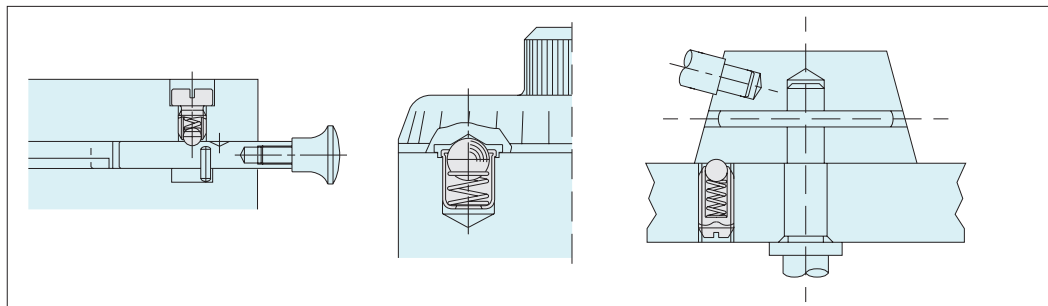

Made of high quality steel and stainless steel, Wixroyd's Spring Plunger range is proven to be reliable for millions of repetitions in securing, positioning, positive locking, indexing and quick release. Their application is limited only by the imagination!

Three push-fit spring plungers no. 32000 have been added to the design of this recessed commercial light fitting. The push-fit design of the plunger makes for easy assembly during production. Their use greatly simplifies the mounting and servicing of the units, reducing handling costs and saving valuable operator time.

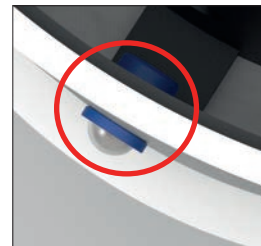

### Commercial Lighting

Used in conjunction with a simple hinge, Wixroyd spring plunger 32300 provides an easy and secure means to positively position and secure the back panel of a blood gas analysis machine. With both brass and stainless steel varieties, our spring plungers have a wide range of application in the medical, pharmaceutical, food and drink processing industries.



### Medical Applications

#### Uses

- For location, applying pressure and "lifting off".
- Securing and positioning.
- Positive locking and indexing.
- Quick release.

#### Industry Sectors

- Machine and fixture design.
- Measuring equipment.
- Electronic components.
- Lighting equipment.
- Medical, optics and orthopaedics.

#### Applications

## Wixroyd Spring Plungers - Uses and Mounting Options

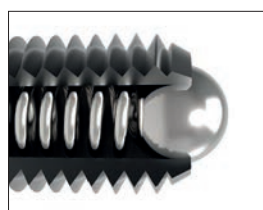

- 31400
- 31420
- 31500
- 32000
- 32100
- 32102
- 32280
- 32300
- 32302
- 32350

#### Mounting Options

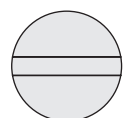

Rear slot

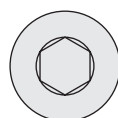

Rear hexagon

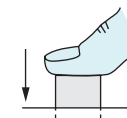

Push fit

#### Ball Type

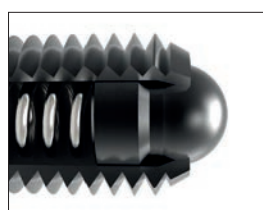

- 31000
- 31600
- 32150
- 32200
- 32220
- 32282
- 32400
- 32420

#### Mounting Options

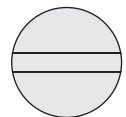

Rear slot

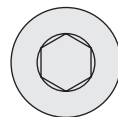

Rear hexagon

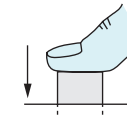

Push fit

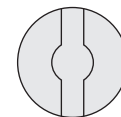

Front slot

#### Pin Head Type



## Quality products every time

### 100% Testing

- Every spring plunger that is produced on the Wixroyd assembly line is individually tested. That is how we guarantee the quality of our products.
- A Wixroyd spring plunger is tested against four key criteria during manufacture.

### Accuracy of 'S' Stroke/ Spring Range



### Accuracy of $f_1$ and $f_2$ Spring Forces



### Accuracy of Ball Diameter

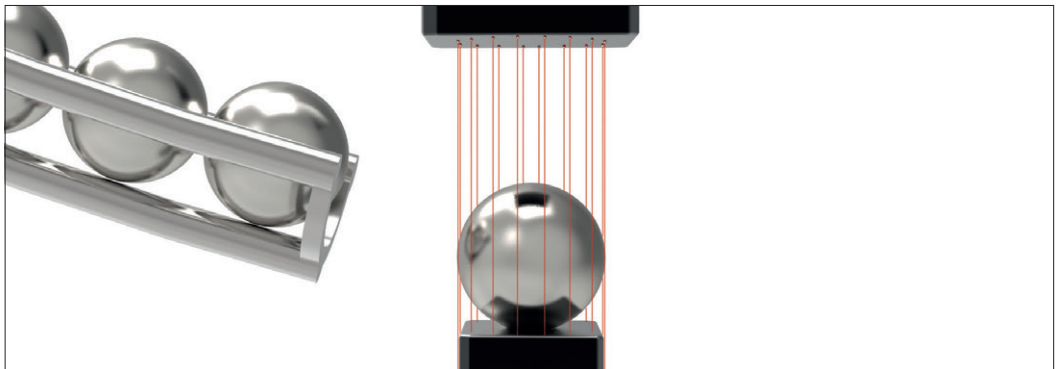

### Accuracy of Thread

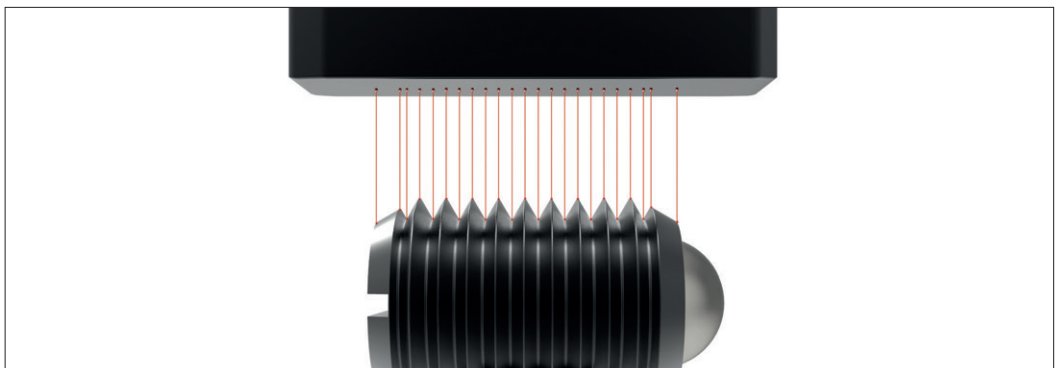



# Wixroyd Spring Plungers

metric thread

31000 - 32420  
Positioning Elements

SPRING PLUNGERS

## Thread Details

All Wixroyd metric spring plungers have a coarse thread.

## Spring Loads

## Typical Spring Repetitions

## Calculating Indexing Resistance

## Electrical Conductivity

## Specials to Your Own Design

	ISO metric coarse threads (mm)															
Thread (D)	3	3,5	4	4,5	5	6	7	8	10	12	14	16	18	20	22	24
Pitch	0,5	0,6	0,7	0,75	0,8	1,0	1,0	1,25	1,5	1,75	2,00	2,0	2,5	2,5	2,5	3,0

- s** Stroke, or movement of plunger's ball or pin.
- f<sub>1</sub>** The force required in Newtons (N) to overcome the static strength of the spring and achieve initial movement of the plunger's ball or pin.
- f<sub>2</sub>** The force required in Newtons (N) to fully compress the spring until the ball or pin is fully depressed against the plunger's body.

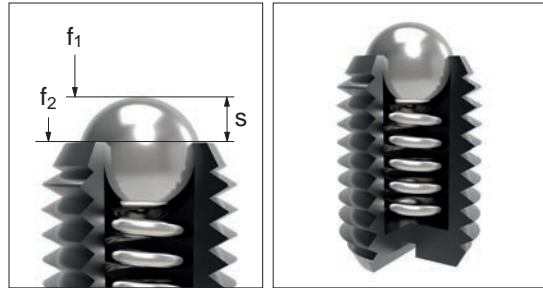

Although dependent upon a number of application specific factors, we are able to give the following guide relating to the maximum number of spring repetitions or cycles of our spring plungers.

- 100% or full stroke "s" used: approx. 300,000 cycles.
- 65% of stroke "s" used: approx 10,000,000 cycles.

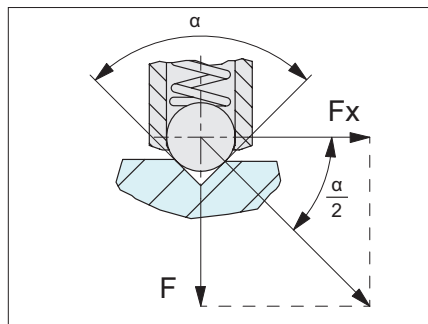
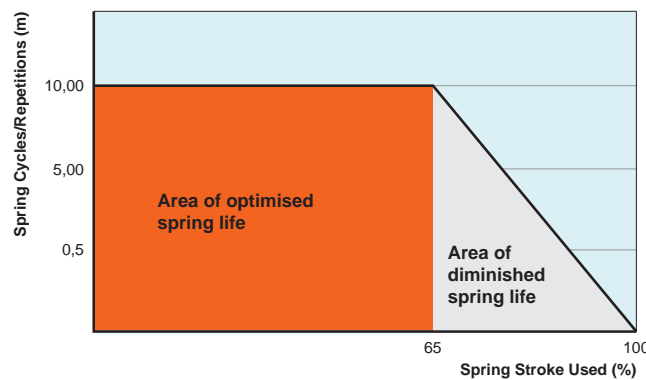

We are able to provide the following formula as an approximation of the pull or push force (N) required to 'release' a ball plunger from its indexing counterpart.

$$F_x = \frac{F}{\tan \frac{\alpha}{2}}$$

$F_x$  = pull or push force (N)  
 $F$  = plungers spring force (see relevant product table)  
 $\alpha$  = angle of the indexing counter part face

**For example:**

For Spring plunger 31500.W0010;  
 $F = 24\text{N}$  (see product table)

**If  $\alpha = 90^\circ$**

$$F_x = \frac{24}{\tan \frac{90}{2}} = 24\text{N}$$

**If  $\alpha = 60^\circ$**

$$F_x = \frac{24}{\tan \frac{60}{2}} = 41,5\text{N}$$

**If  $\alpha = 120^\circ$**

$$F_x = \frac{24}{\tan \frac{120}{2}} = 13,8\text{N}$$

**Important Note: This is only an approximation formula. For more accurate calculation the roughness of the counterpart surface as well as any variation in the plungers spring force (due to age or high repetitions) should be considered.**

We are often asked the electrical conductivity of our spring plungers, unfortunately we are unable to provide any reliable information related to this as there are many factors in an application. We recommend you study the specific material properties of the spring plunger's component parts to make your own calculations, alternatively if in doubt make a test application.

Manufacturing exactly to your specific requirements is also our strength. If you need a variation in spring pressure, plunger body or pin design we can assist with a special design item for volumes as low as 1,000 units.

For further information, or to request a quotation, please call our sales office on 0333 207 4497.